

ESTABILIDAD
DE LAS
CONSTRUCCIONES
DE
MAMPOSTERÍA

POR
E. BOIX

INGENIERO JEFE DE CAMINOS, CANALES Y PUERTOS

MADRID

ESTABLECIMIENTO TIPOGRÁFICO DE G. JUSTE

Calle de Pizarro, núm. 15, bajo

1889

Fig. 1.

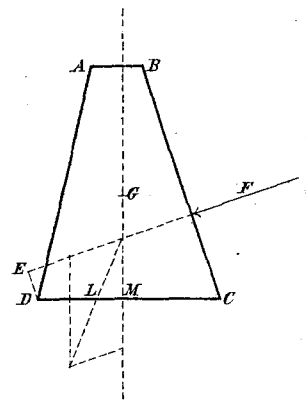

Fig. 3.

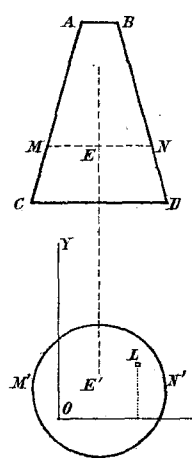

Fig. 6.

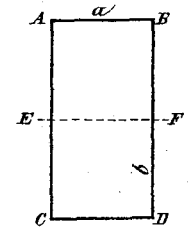

Fig. 8.

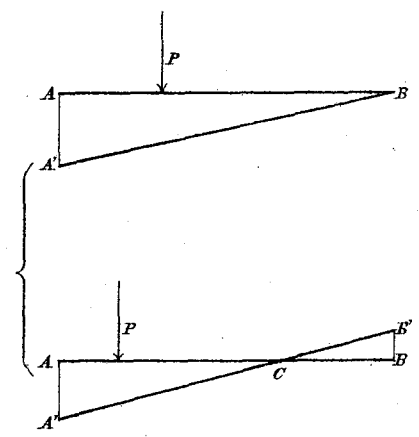

Fig. 2.

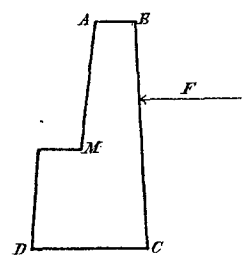

Fig. 7.

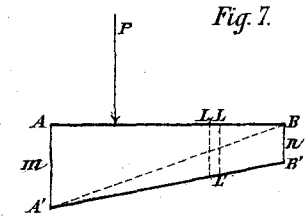

Fig. 10.

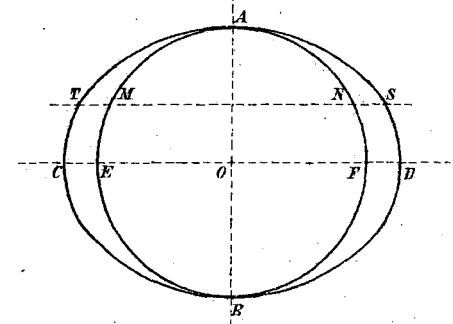

Fig. 4.

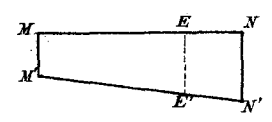

Fig. 5.

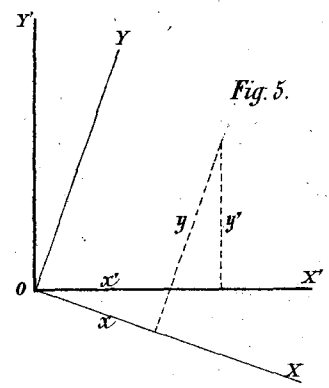

Fig. 9.

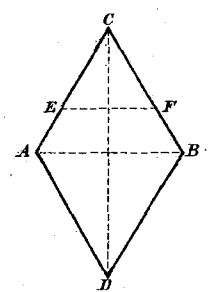

Fig. 11.

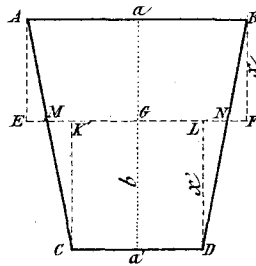

Fig. 14.

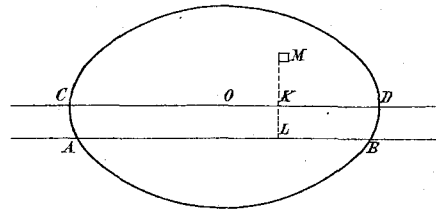

Fig. 18.

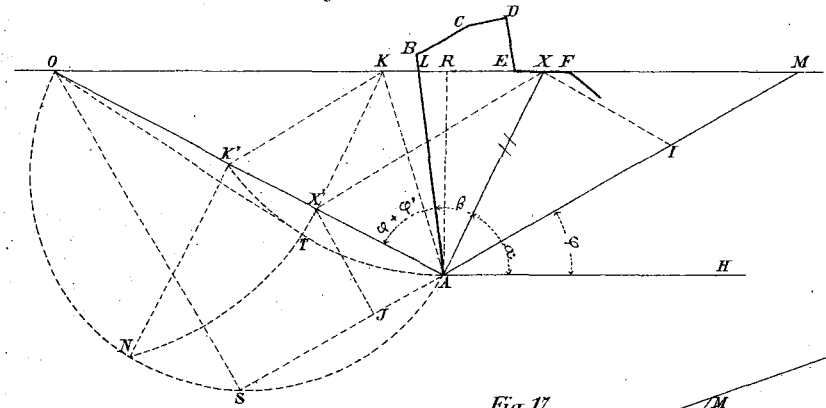

Fig. 12.

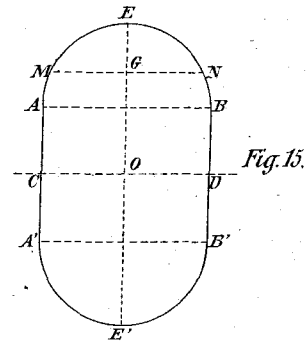
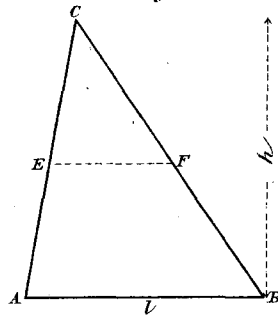

Fig. 15.

Fig. 17.

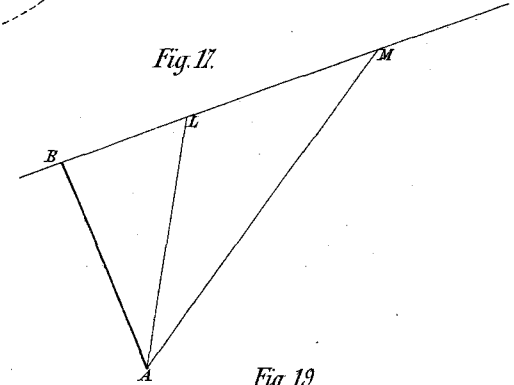

Fig. 13.

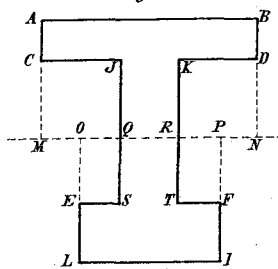

Fig. 16.

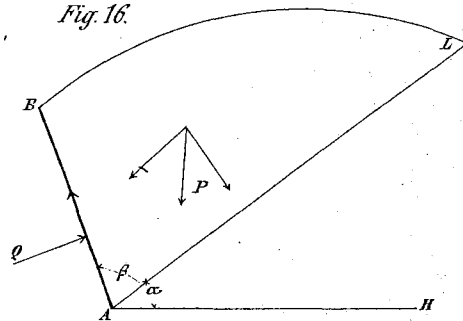

Fig. 20.

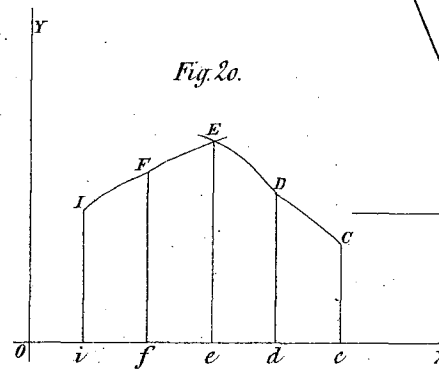

Fig. 19.

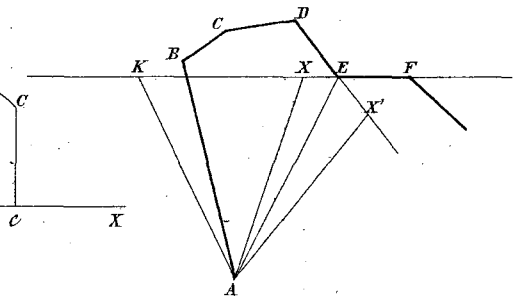

Fig. 21.

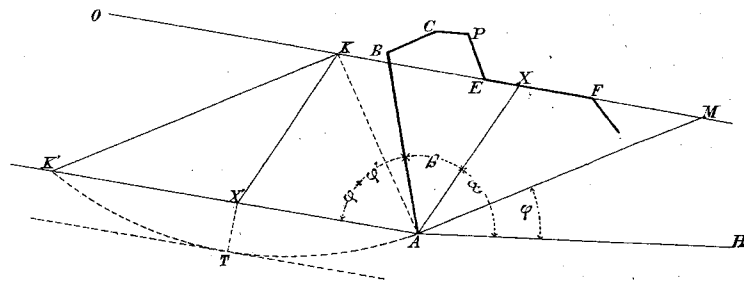

Fig. 24.

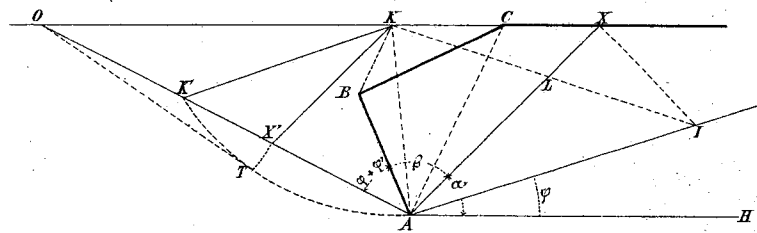

Fig. 25.

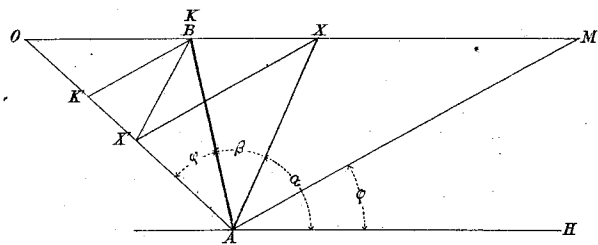

Fig. 23.

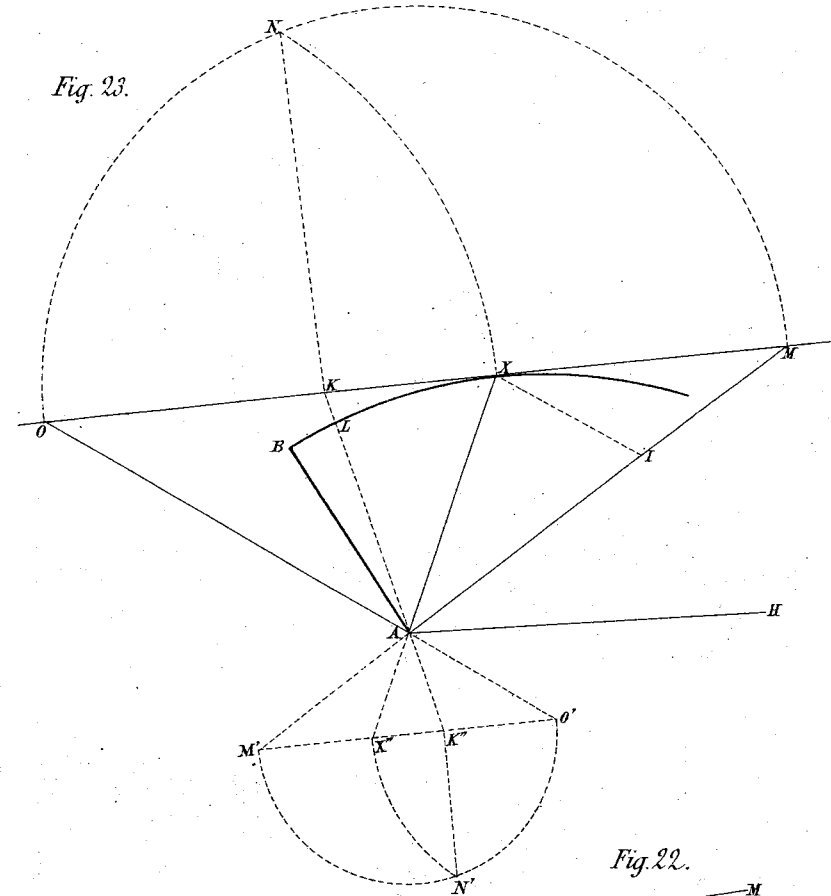

Fig. 22.

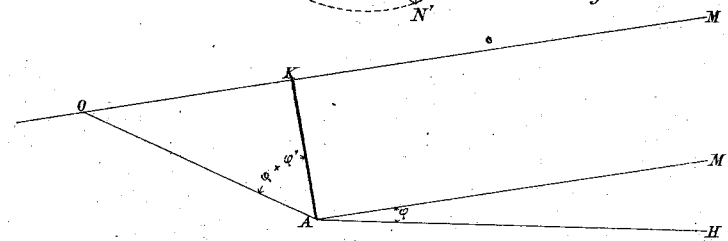

Fig. 26.

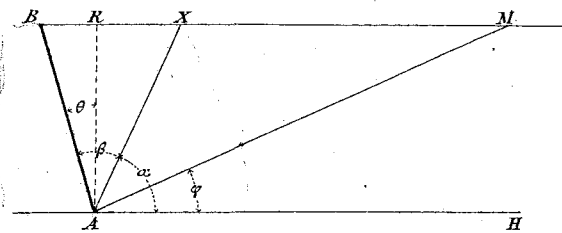

Fig. 31.

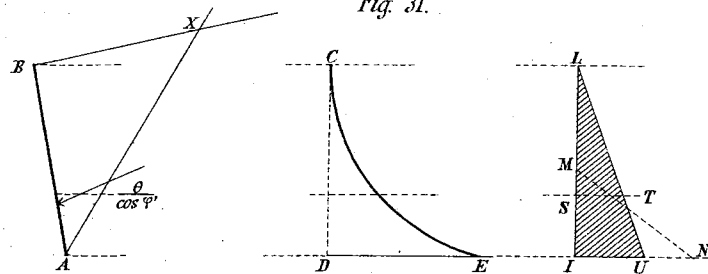

Fig. 30

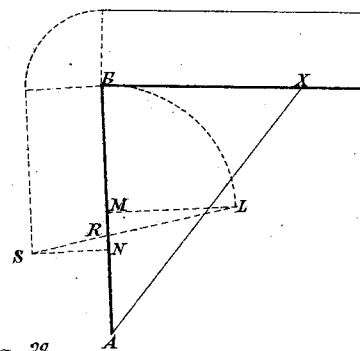

Fig. 29.

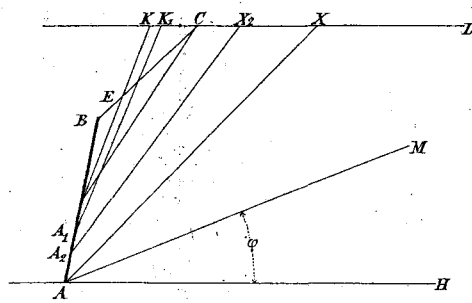

Fig. 32.

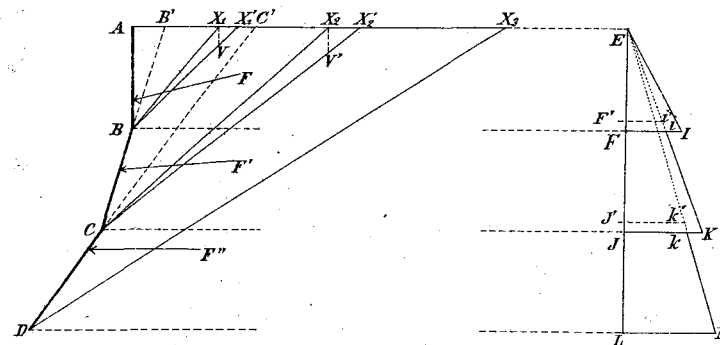

Fig. 27.

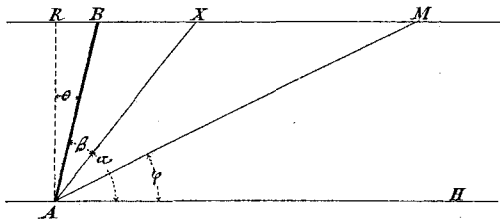
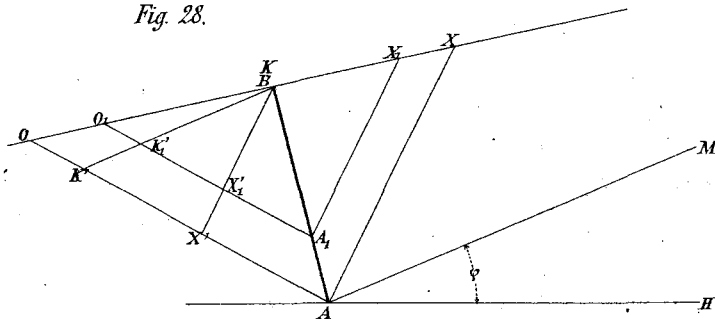
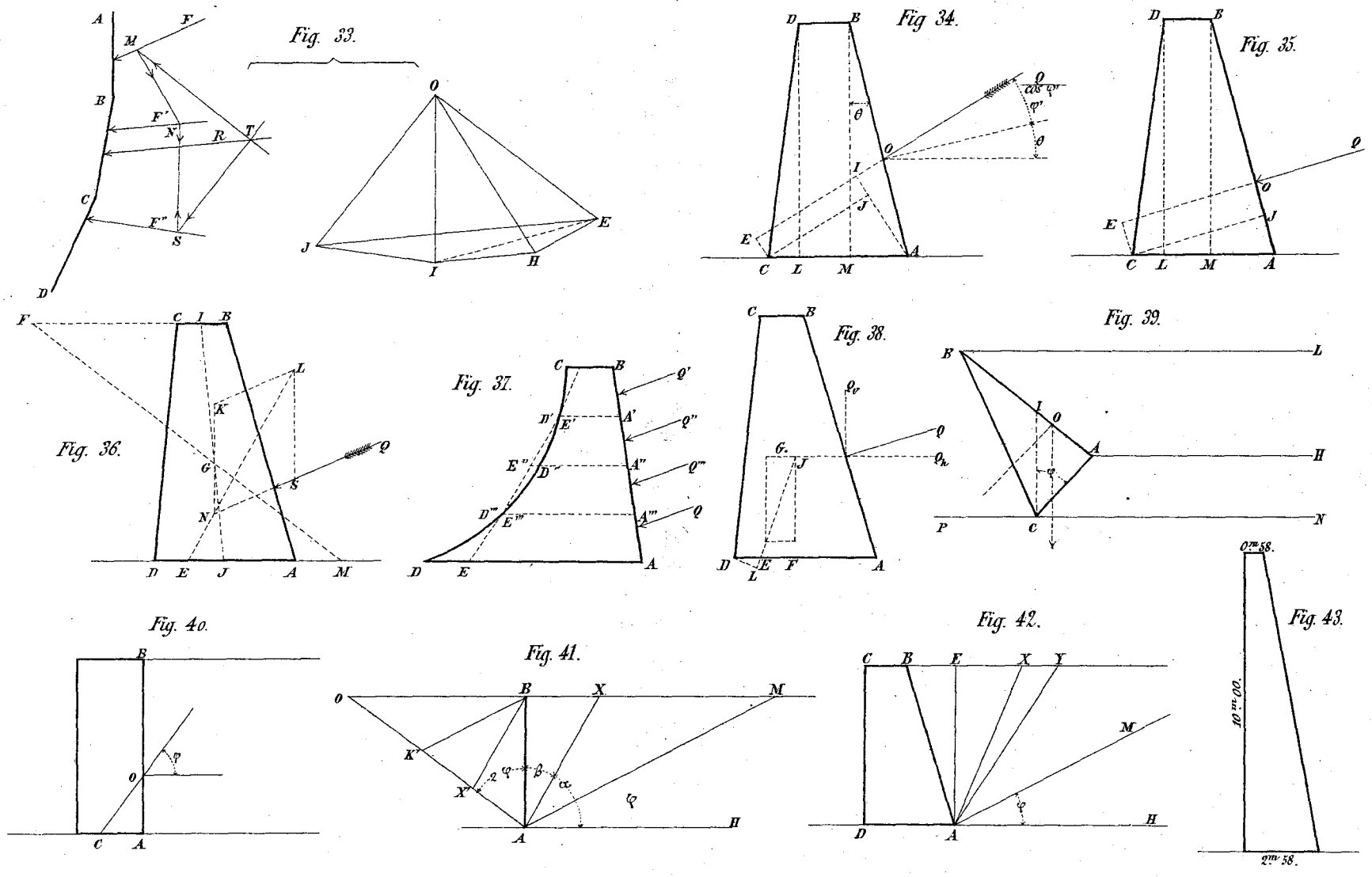
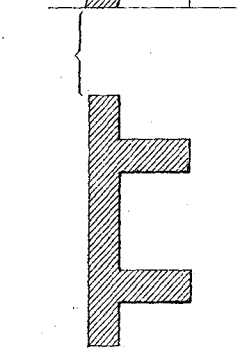
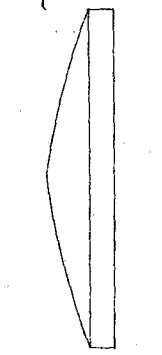
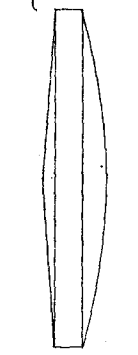
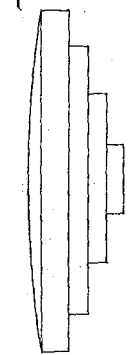
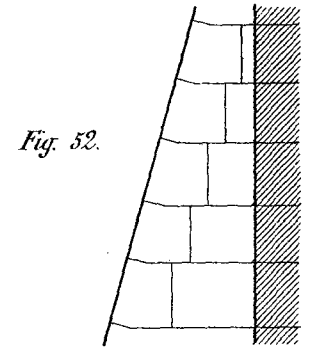
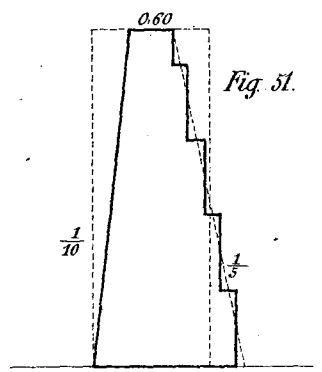
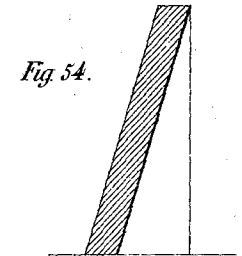
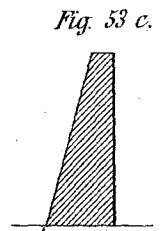
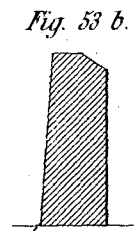
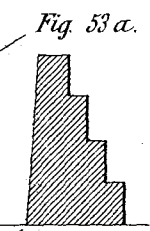
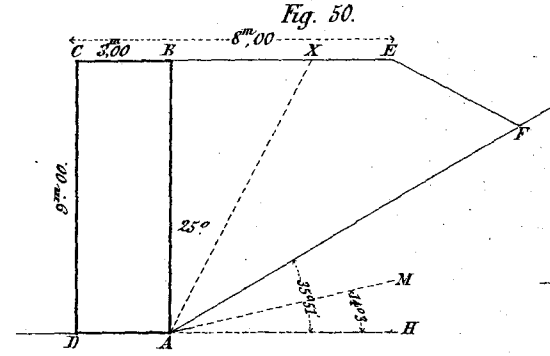
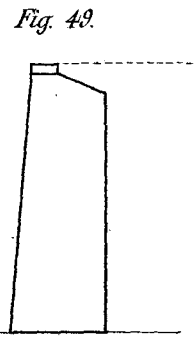
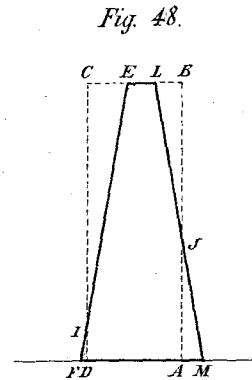
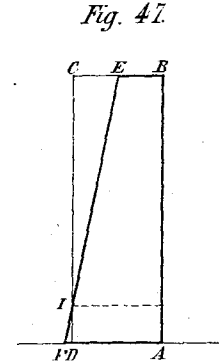
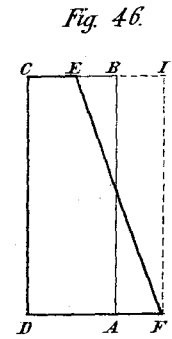
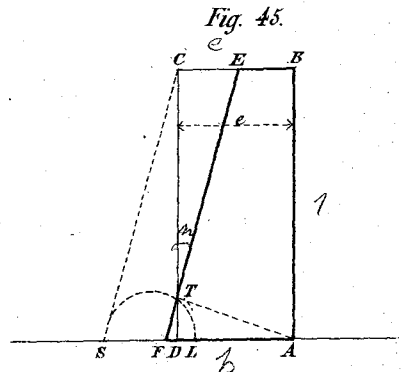
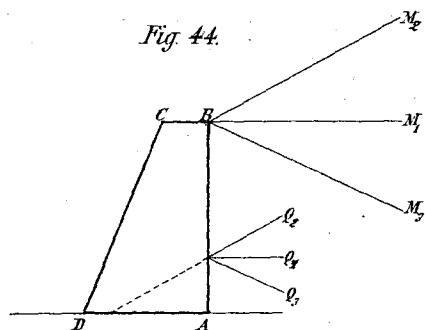
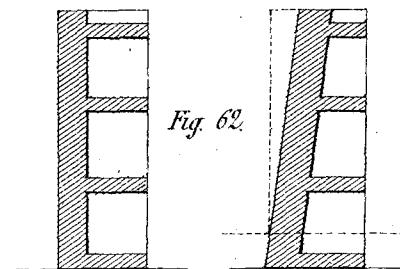
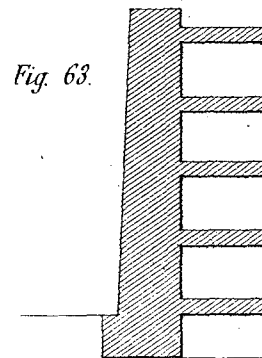
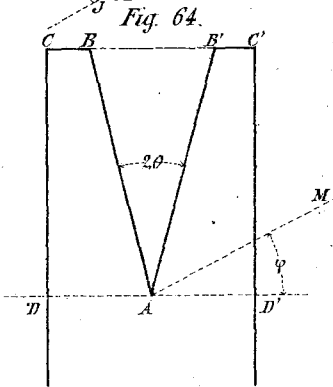
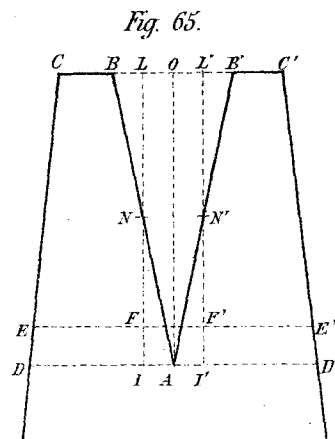
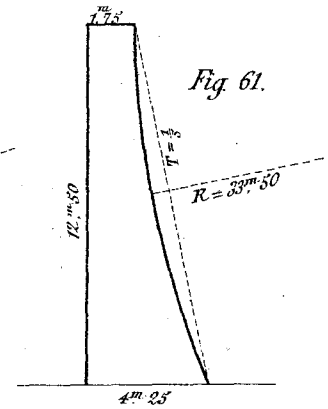
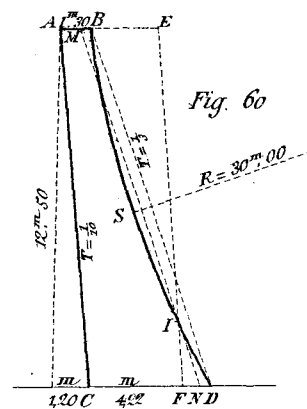
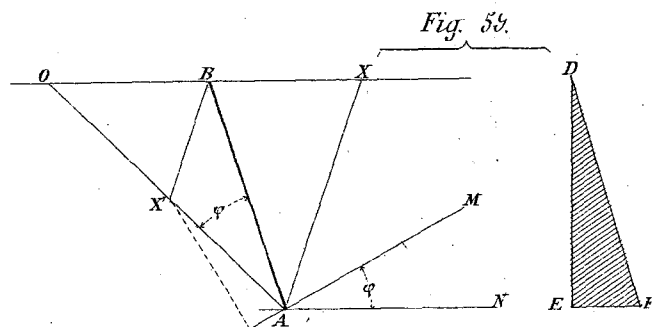
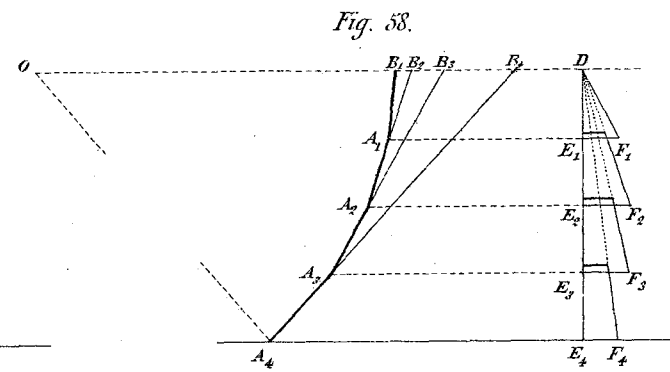
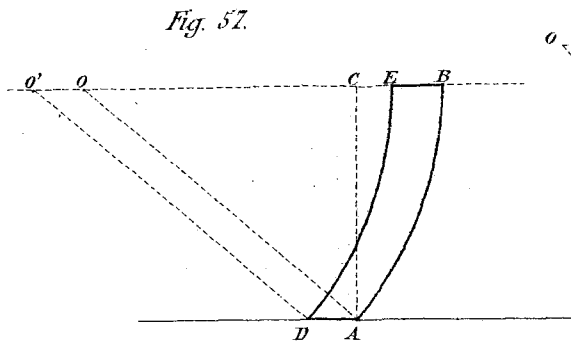
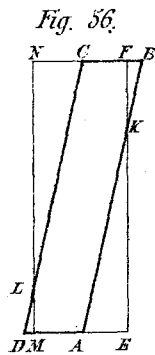
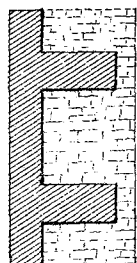
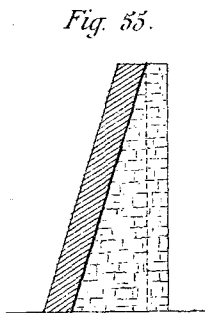

Fig. 28.









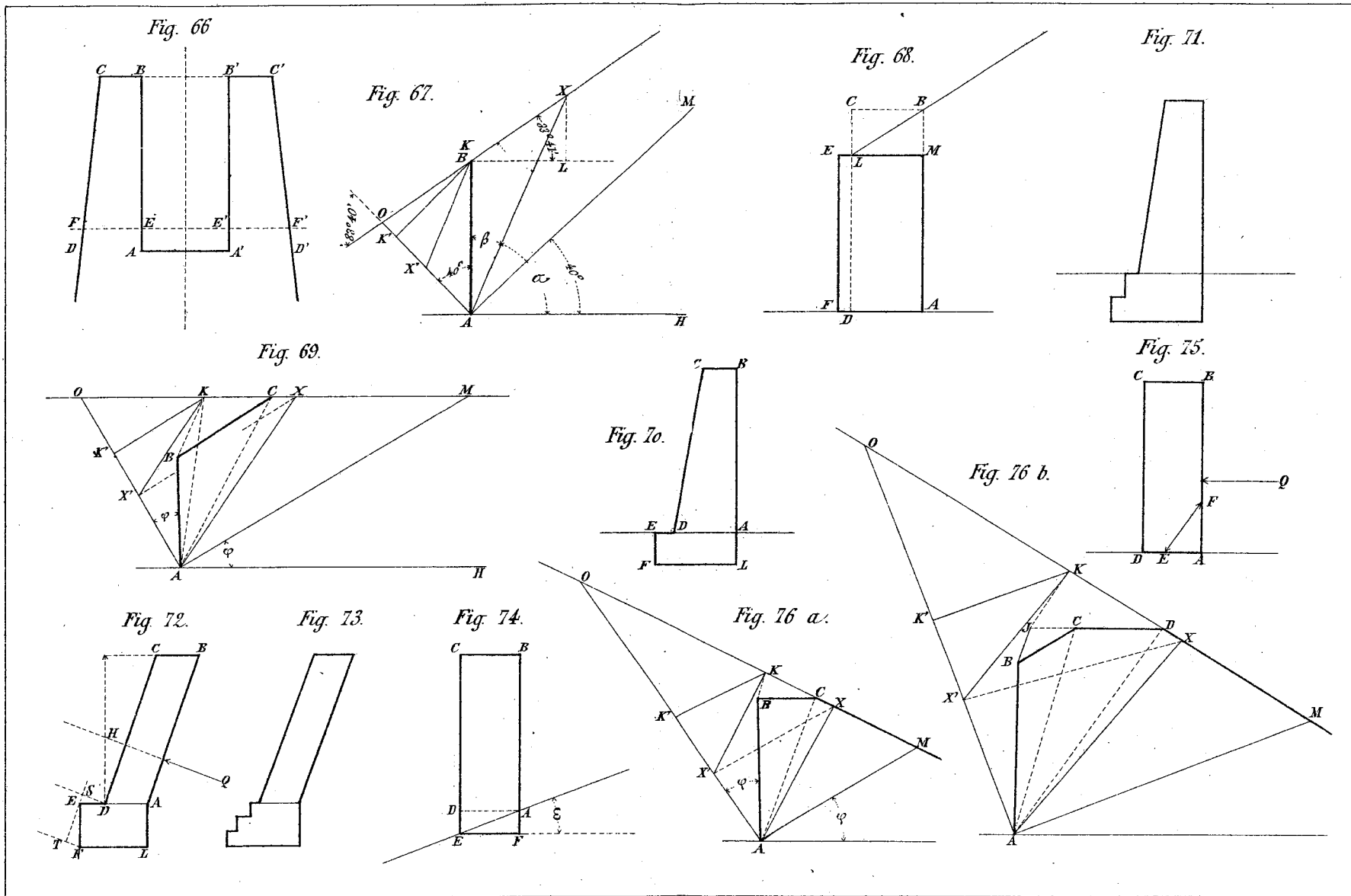

Fig. 77.

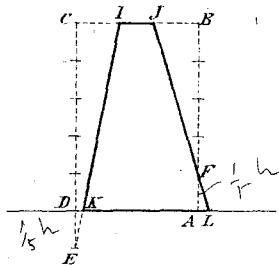

Fig. 78.

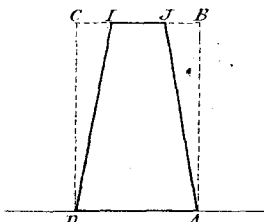

Fig. 79.

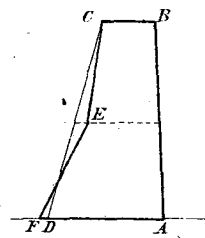
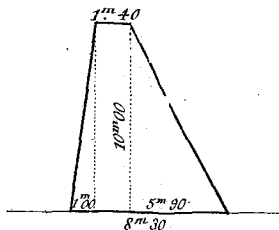

Fig. 81

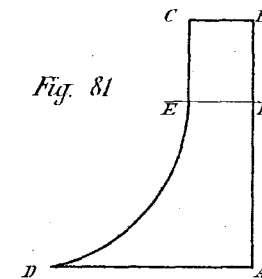

Fig. 83.

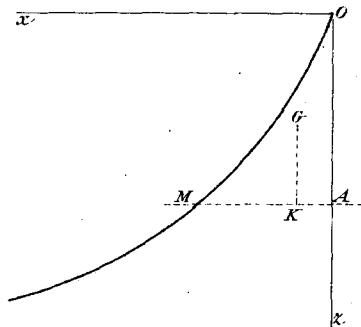

Fig. 84.

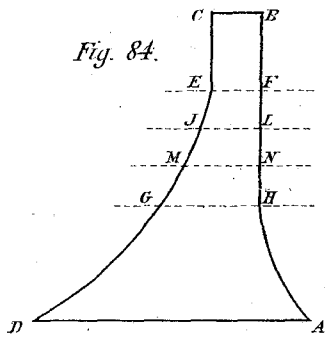

Fig. 85.

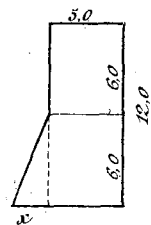

Fig. 80.

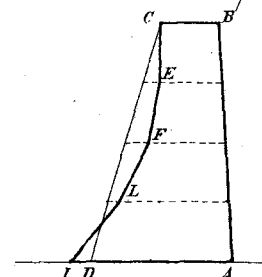

Fig. 82.

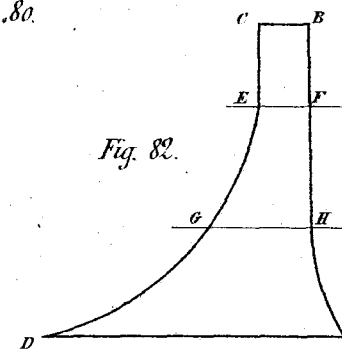

Fig. 86.

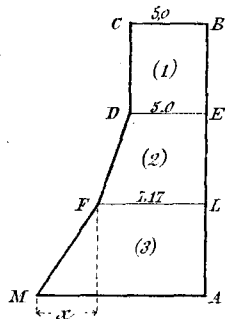

Fig. 87.

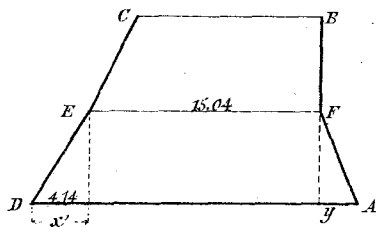

Fig. 80.

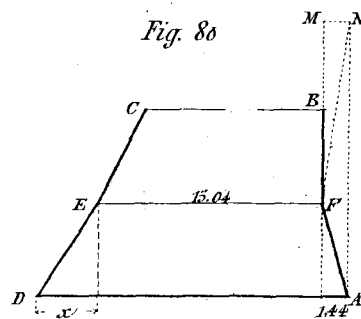

Fig. 89.

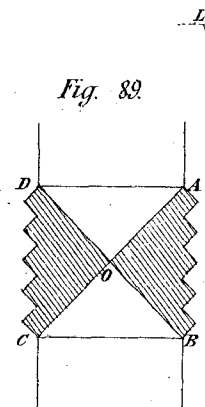
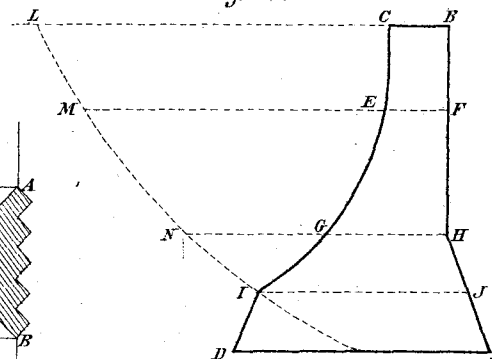
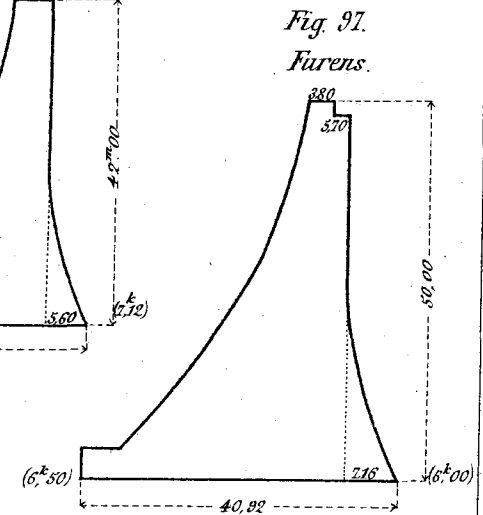
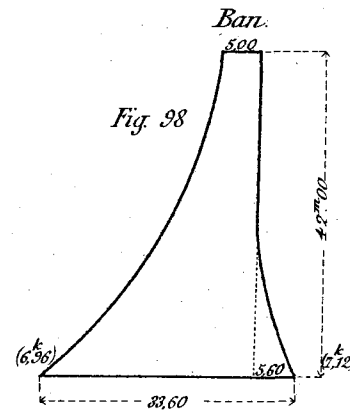
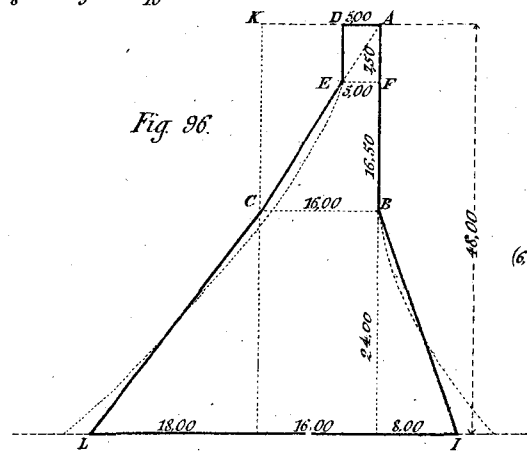
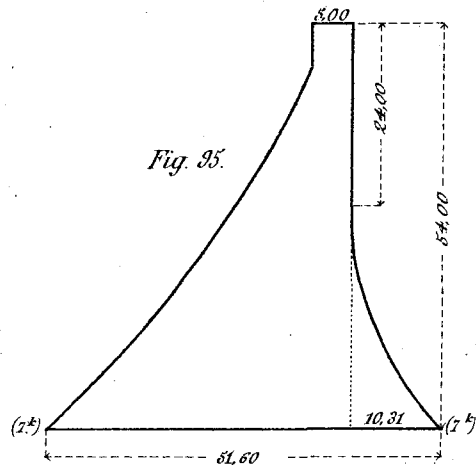
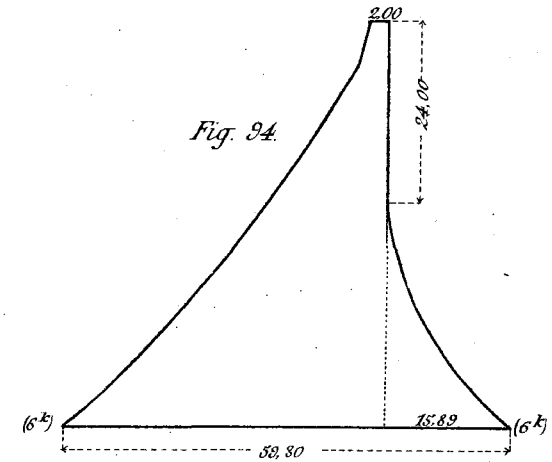
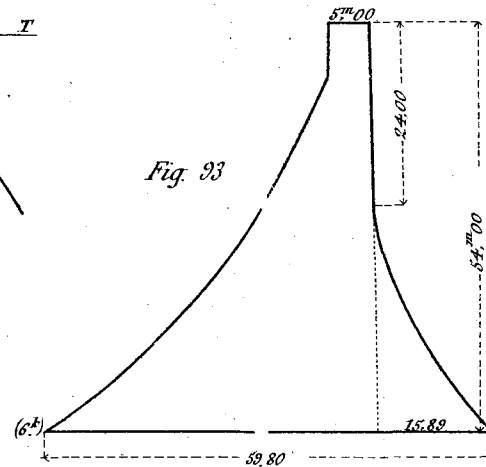
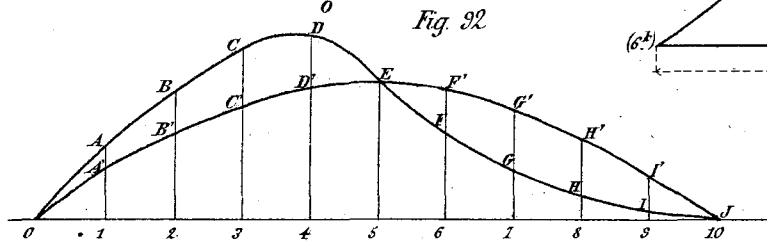
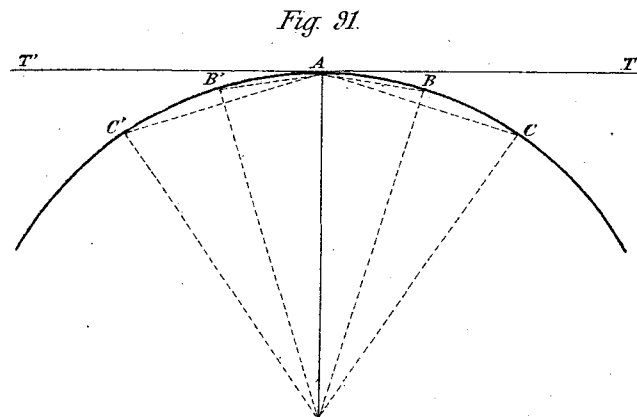

Fig. 90.





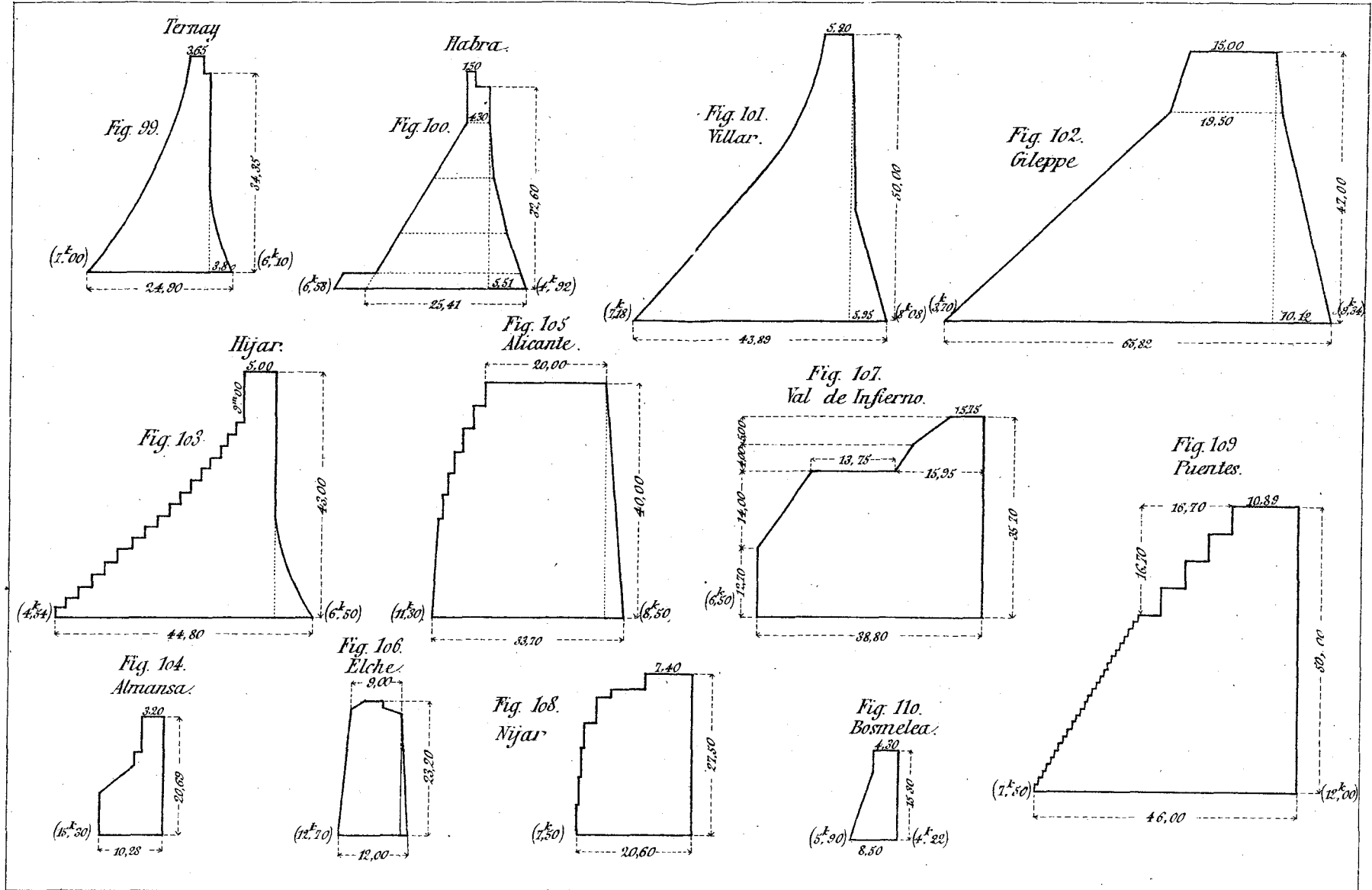

Fig. 111.

Lampy.

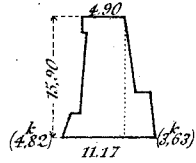

Fig. 112.

Gros-bois.

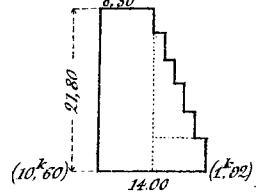

Fig. 113.

Gronel.

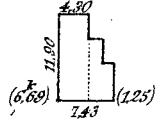
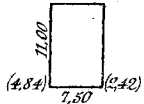

Fig. 114.

Vioreau



Krantz

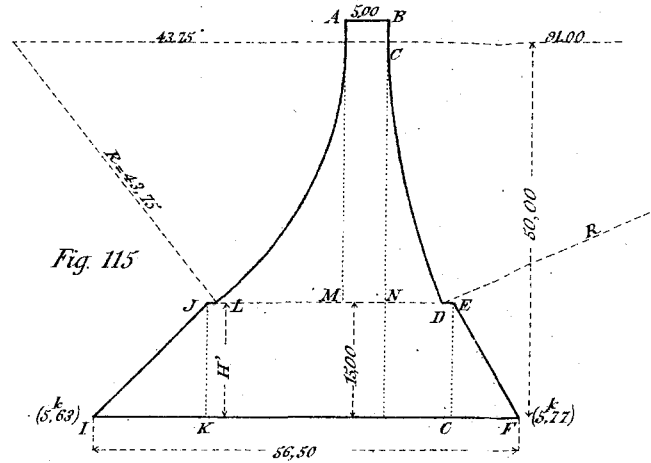

Fig. 115

Fig. 118.

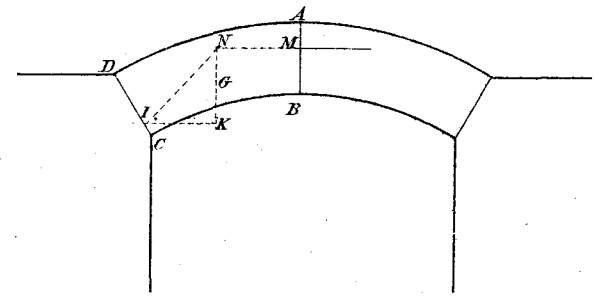

Fig. 119.

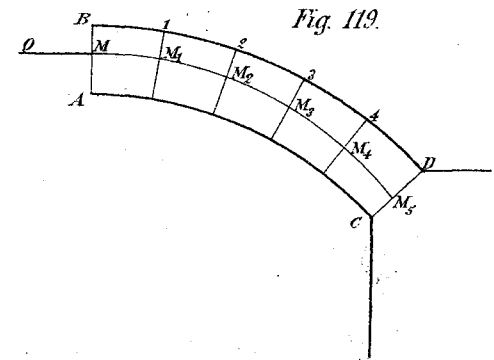

Fig. 120.

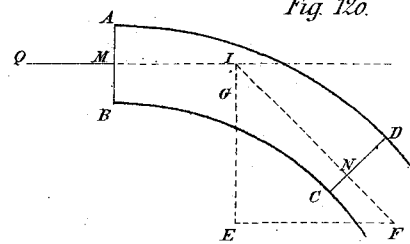

Fig. 116

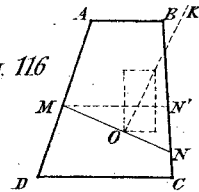

Fig. 117.

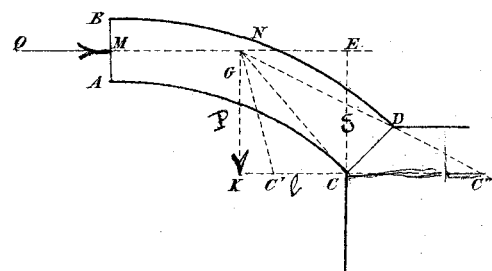
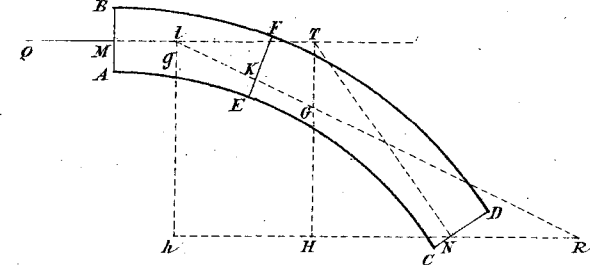
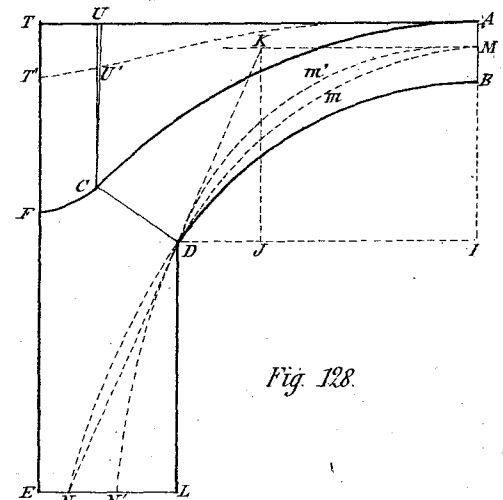
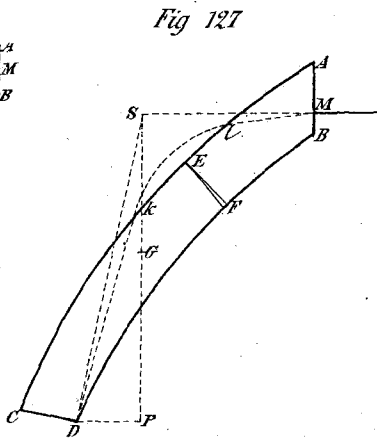
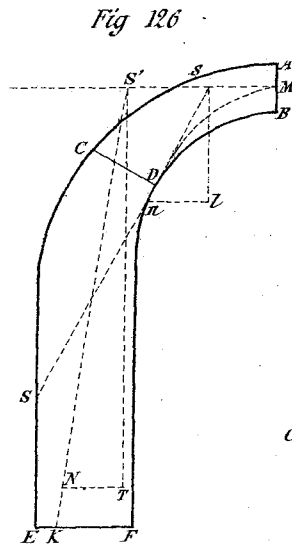
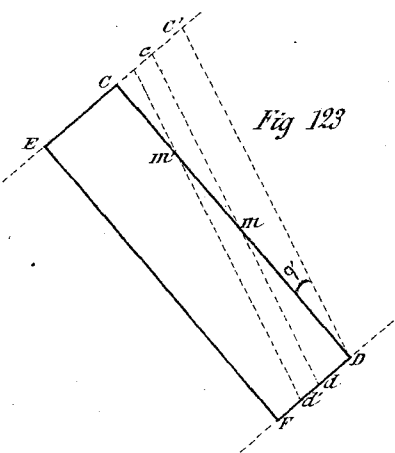
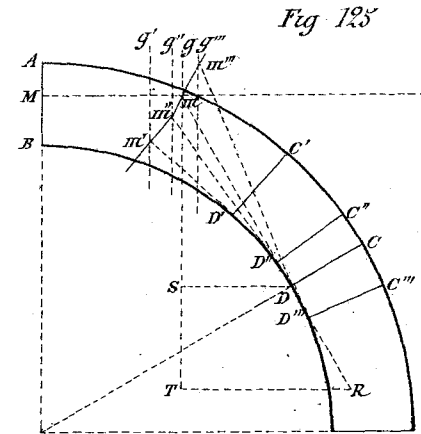
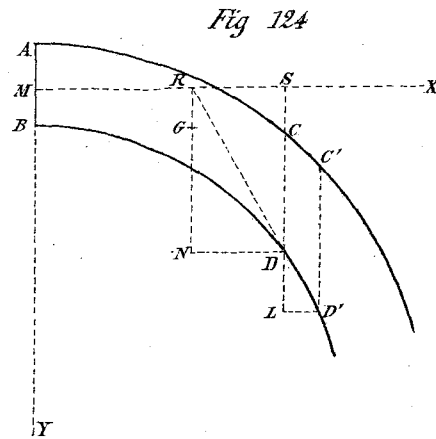
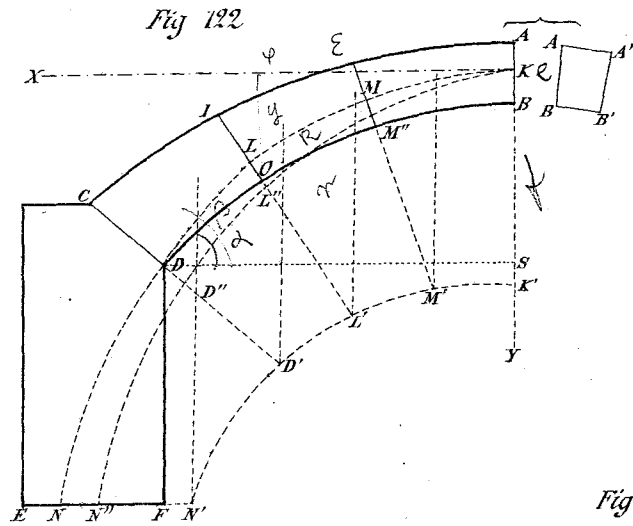

Fig. 121.





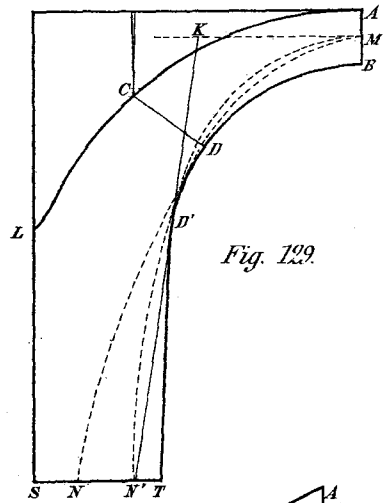

Fig. 129.

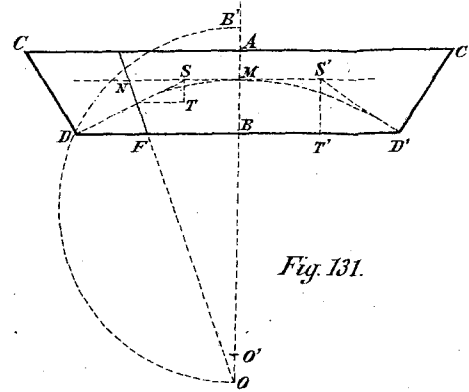

Fig. 131.

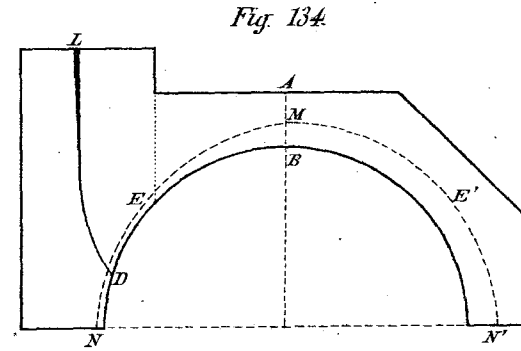

Fig. 134.

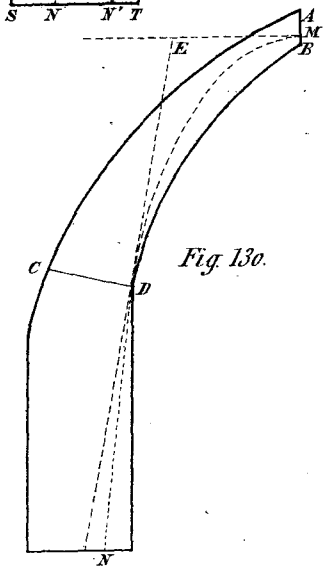

Fig. 130.

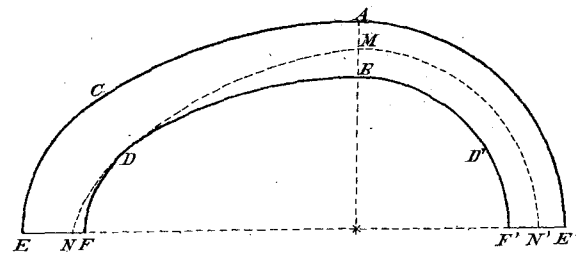

Fig. 132.

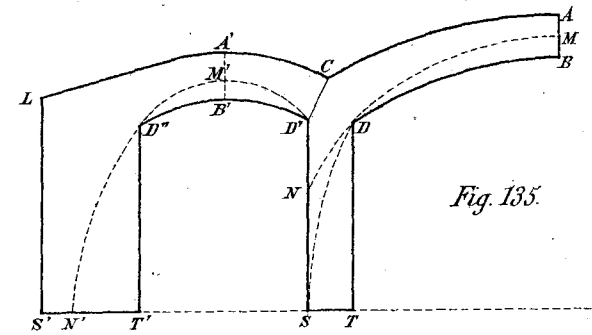

Fig. 135.

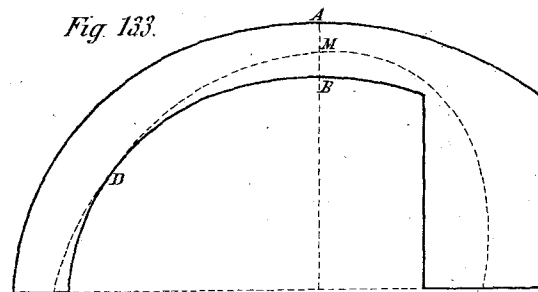

Fig. 133.

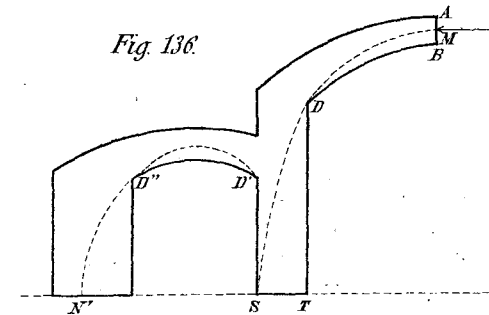

Fig. 136.

Fig. 137.

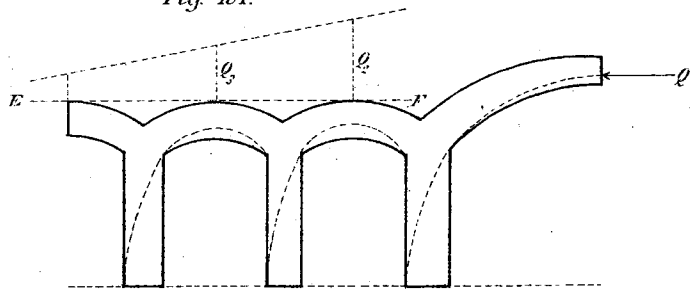

Fig. 140.

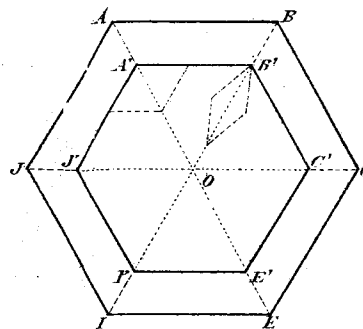

Fig. 143.

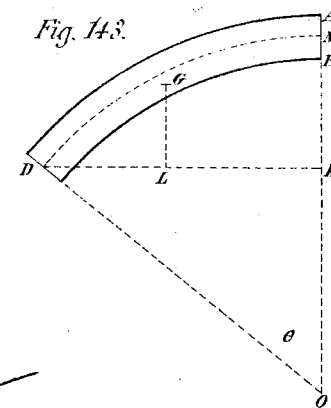

Fig. 138.

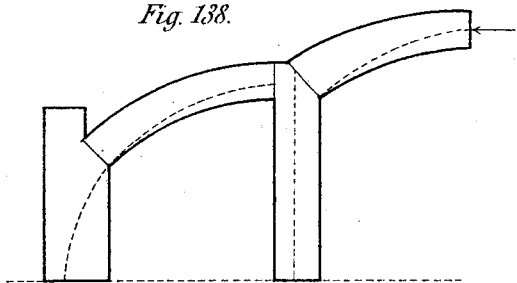

Fig. 141.

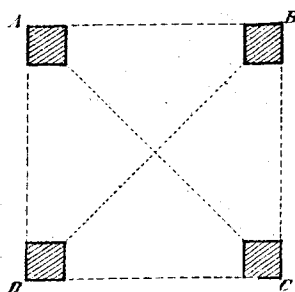

Fig. 144.

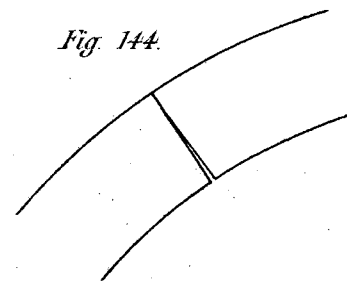

Fig. 145.

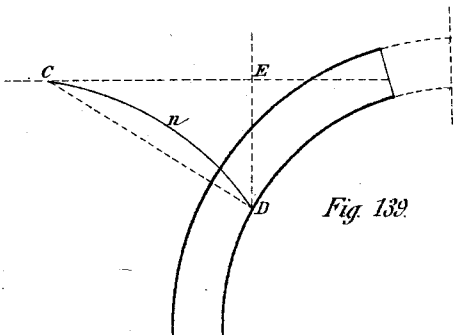
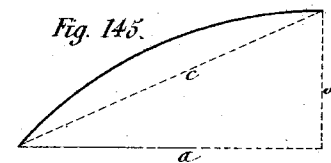

Fig. 139.

Fig. 142.

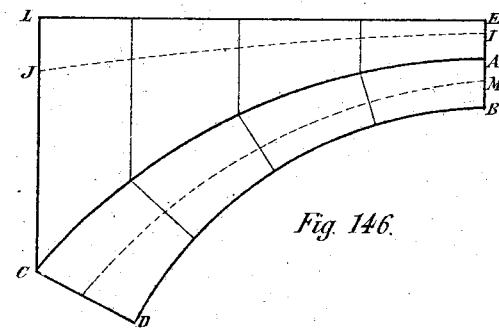
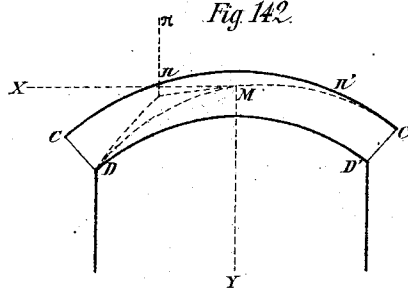

Fig. 146.

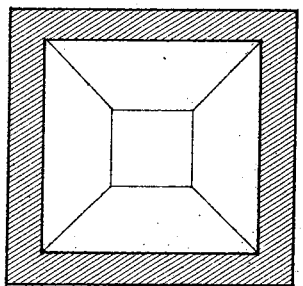
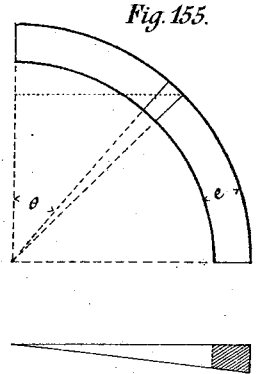
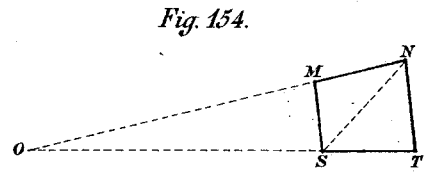
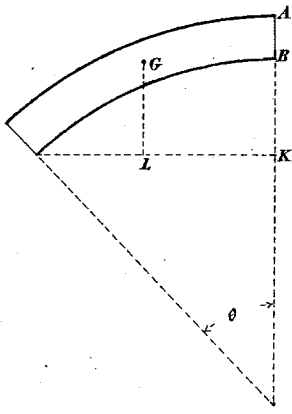
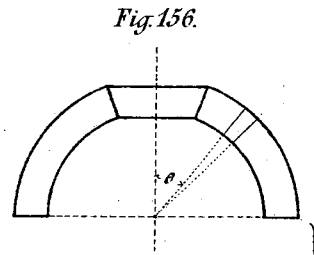
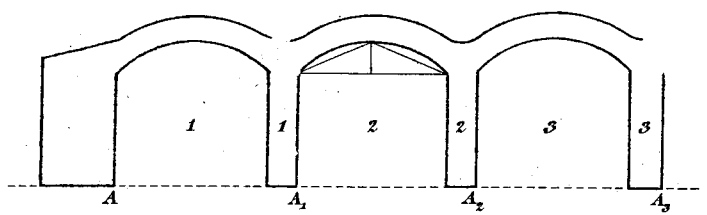
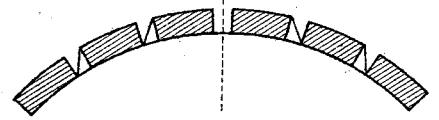
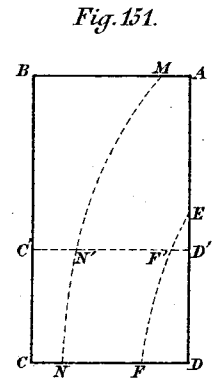
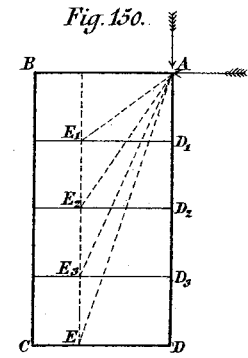
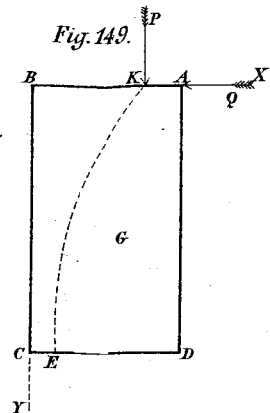
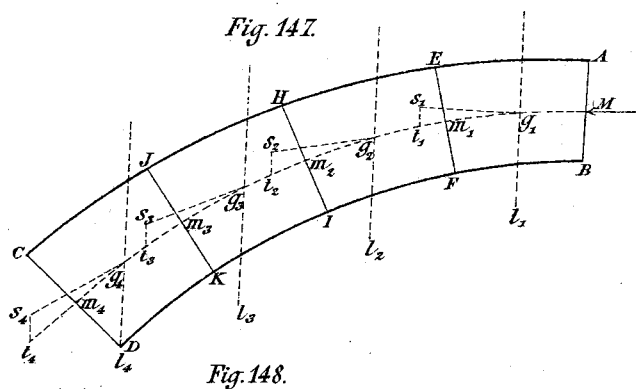

Fig. 157.

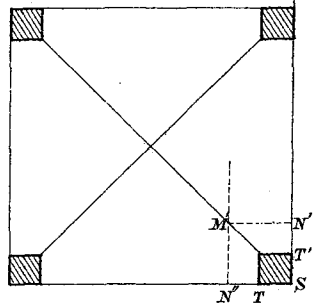
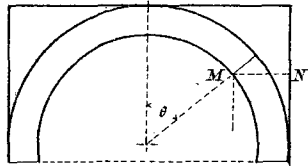

Fig. 158.

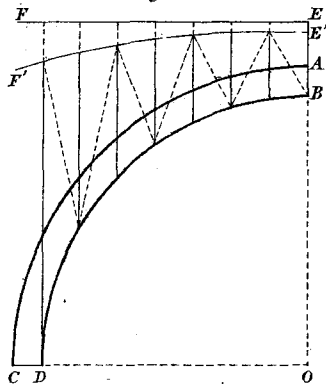

Fig. 159.

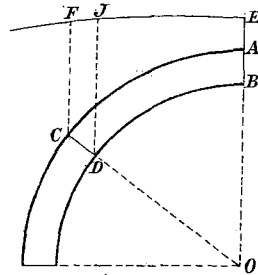

Fig. 162.

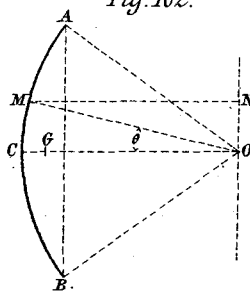

Fig. 165.

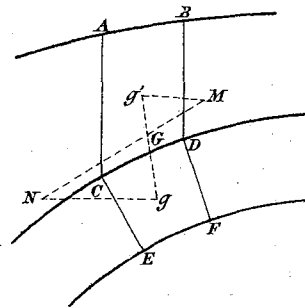

Fig. 160.

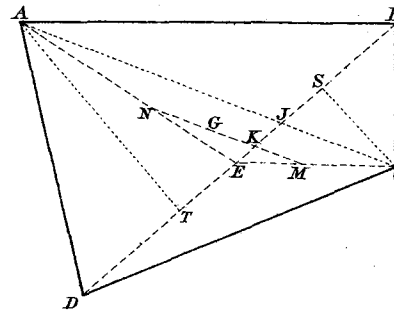

Fig. 163.

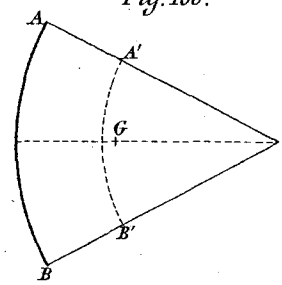

Fig. 166.

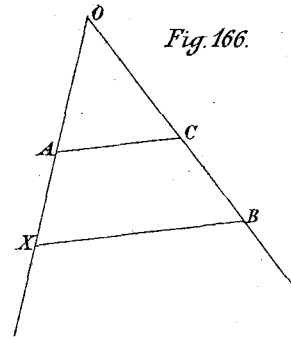

Fig. 161.

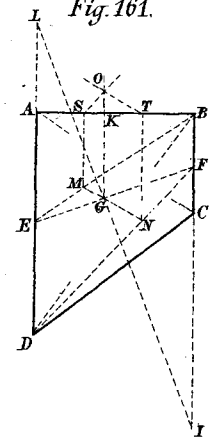

Fig. 164.

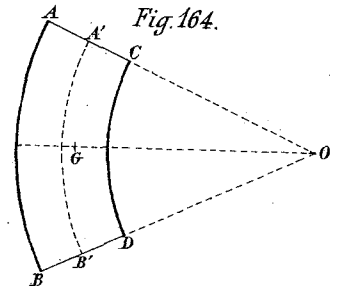
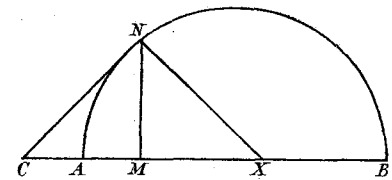
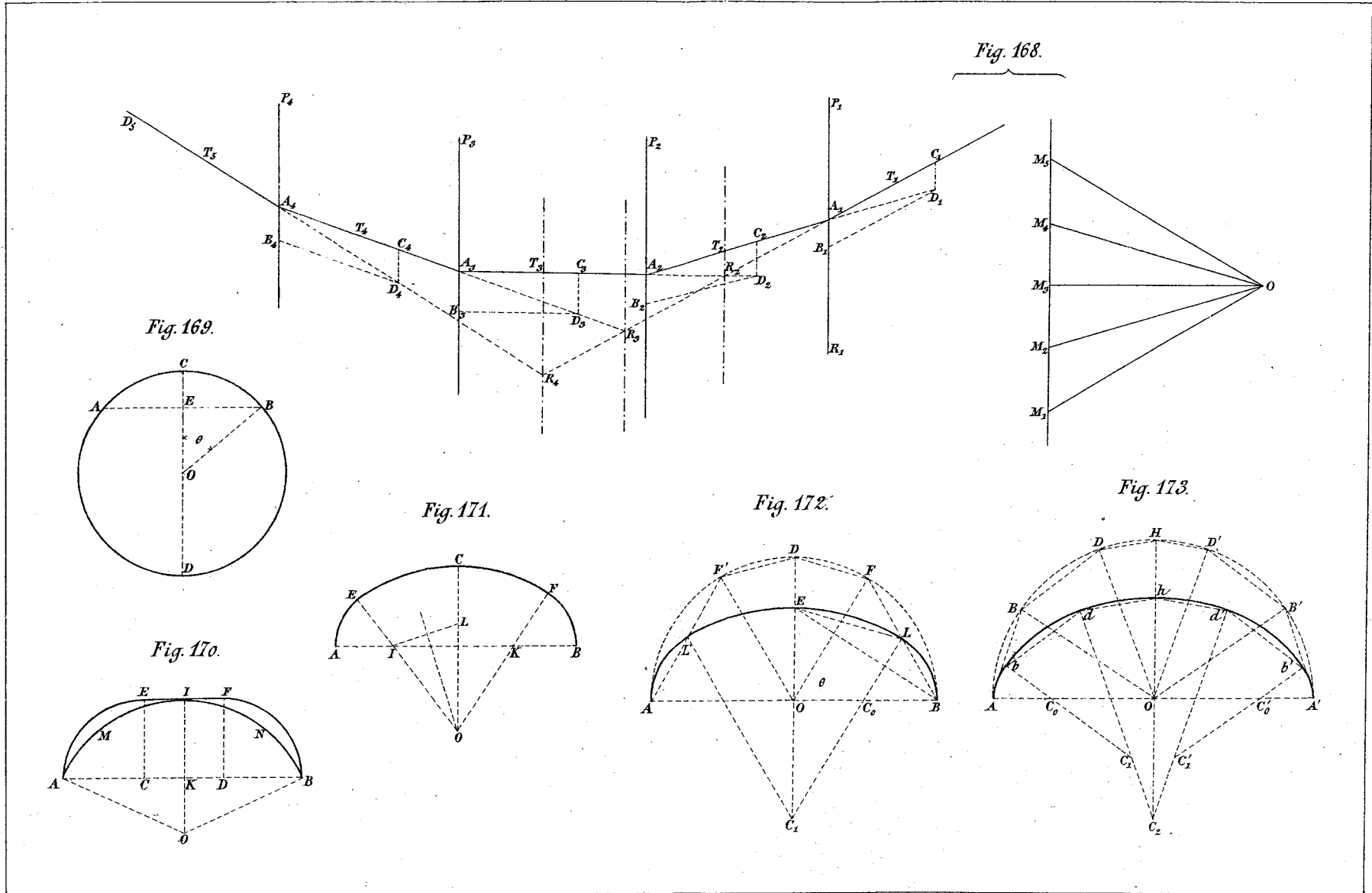

Fig. 167.





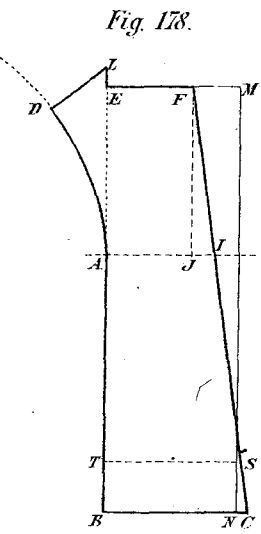
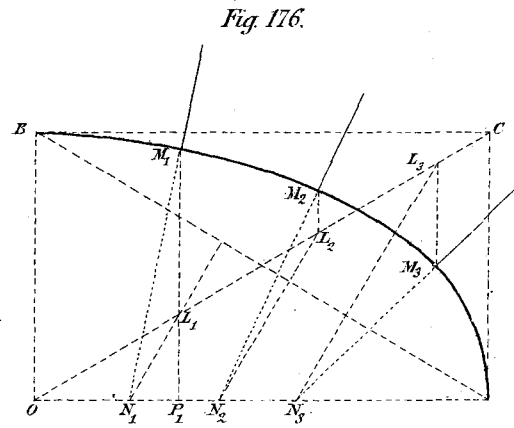
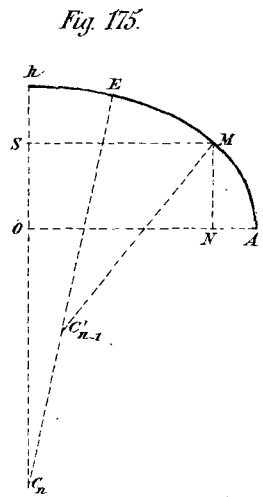
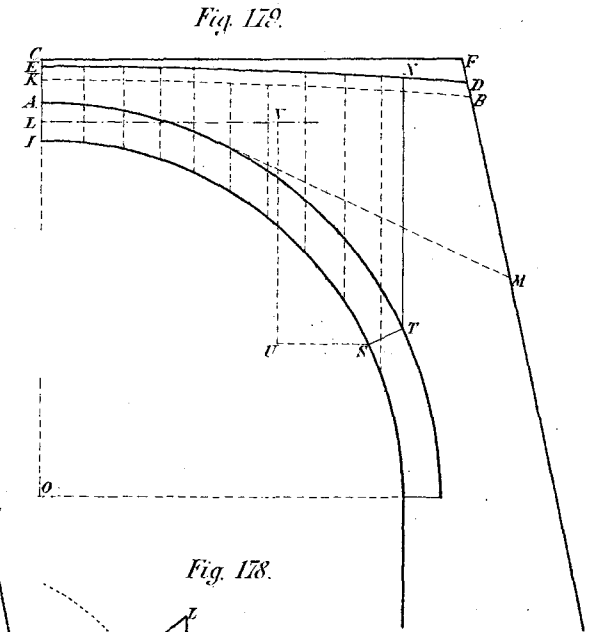
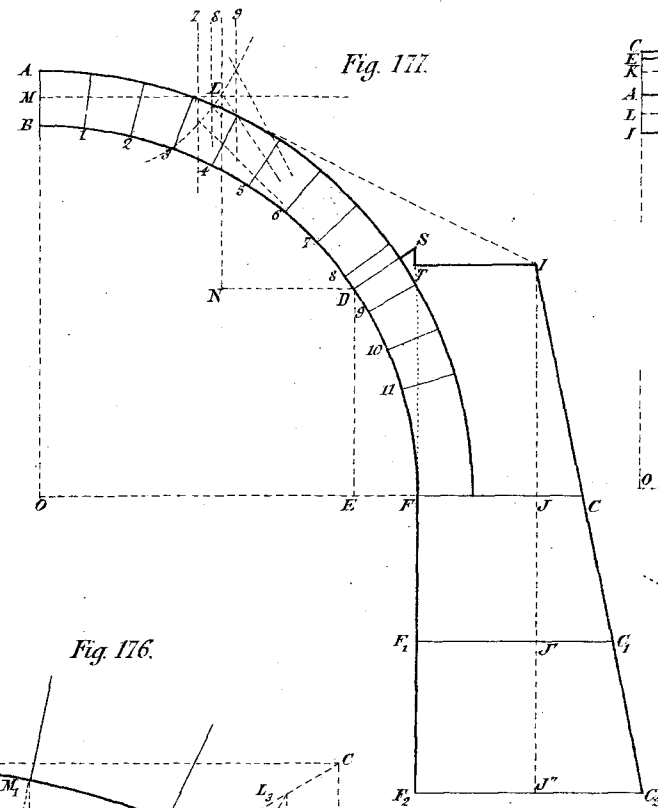
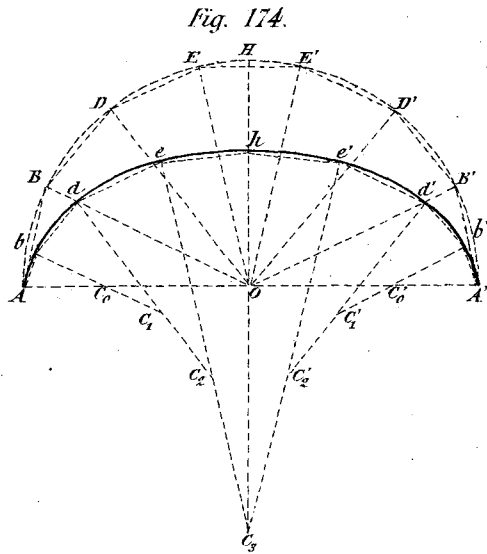

Fig. 180.

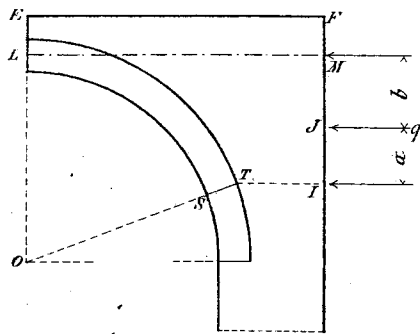

Fig. 183.

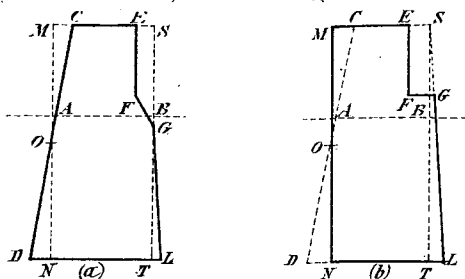

Fig. 184.

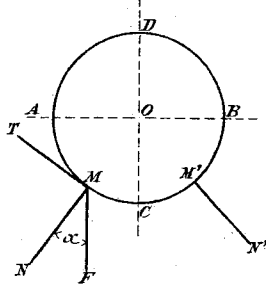

Fig. 186.

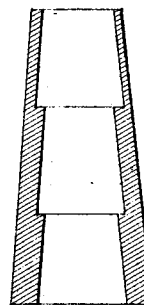

Fig. 188.

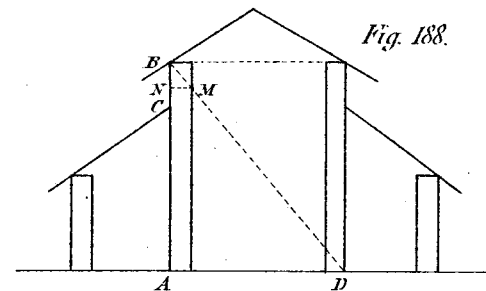

Fig. 187.

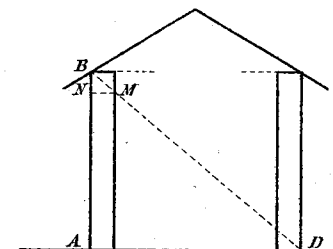

Fig. 181.

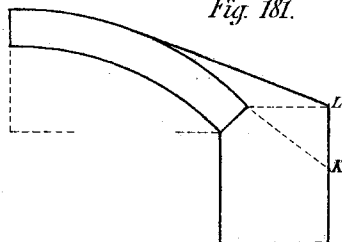

Fig. 182.

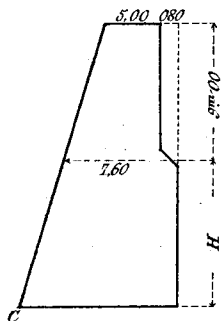

Fig. 185.

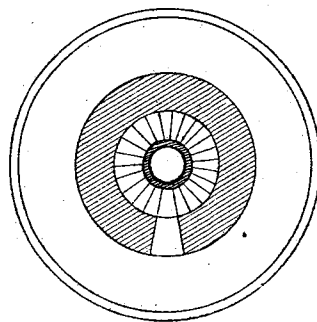

Fig. 189.

